

				A-MAX Technology Co,Ltd.			
				TITLE: BLOCK DIAGRAM		DWGNO:	
				BLOCK/VERSION:		MODEL: 06FP05	
		DATE: 2006/02/16	SHEET: 1 OF 8	REVISION: LOW		FILE NAME: SCH-DA	
		DWN/DATE:	CHK/DATE:	APP/DATE:			
NO.	DATE	REVISION RECORD					

6

5

4

3

2

1

******* Sigmatel 35xx Full Function Schematics *******

Revised History

- 1), Rev.1.0W New Released 2006-3-11
- 2), Rev.1.1W Released 2005-03-29
 - 1.changed Q5 XP151 to XP152;
 - 2.Add R55 10k and R58 0 ohm;
 - 3.Change R16,R21,R22 47k to 10k;
 - 4.Change R14,R15 47k to 2.2k;
 - 5.Add R59,R60,R62 47k;
 - 6.Change C79 10u to 1u 0603;
 - 7.Add Q6 3904;
 - 8.Delete JP1 0 ohm and connect FM_GND to GND;
 - 9.Add Q7 NTJD2152P
- 2), Rev.1.2 Released 2005-04-26

Table of contents

- Page1: Title
- Page2: Stmp35xx
- Page3: Flash
- Page4: Buttons
- Page5: USB/Audio
- Page6: TFT Display
- Page7: FM Tuner

A-MAX Technology Co.Ltd

Title: TITLE			
Model	06FP05	Version	VER:1.0W
Drawn By		Date	
Checked By		Date	
Approved By		Date	
SHEET:2 OF 8			

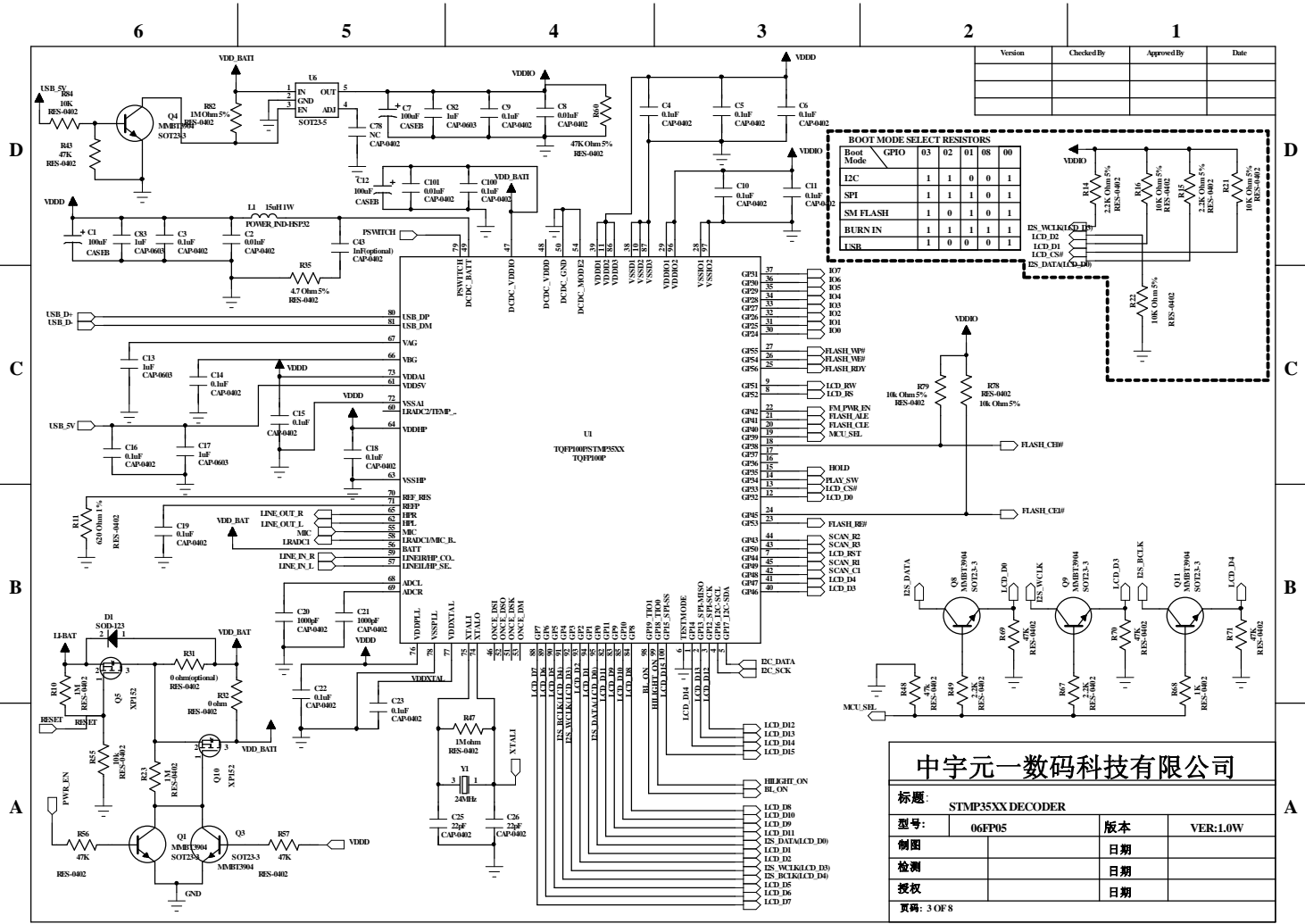

中宇元一数码科技有限公司

标题: **STM32XXX DECODER**

型号:	06FP05	版本:	VER:LOW
制图:		日期:	
检测:		日期:	
授权:		日期:	

页码: 3 OF 8

6

5

4

3

2

1

Version	Checked By	Approved By	Date

D

D

C

C

B

B

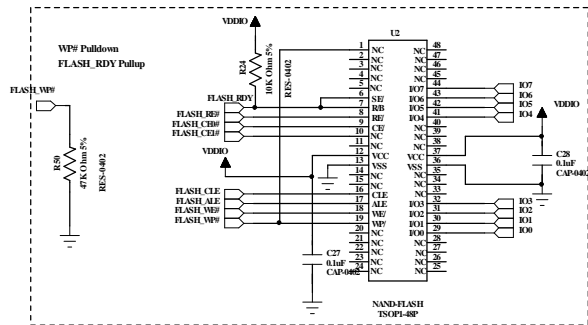

A

A

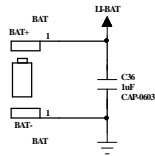

A-MAX Technology Co.Ltd

Title: NAND FLASH			
Model: 06FP05	Version:	Ver: L0W	
Drawn By:		Date:	
Checked By:		Date:	
Approved By:		Date:	
SHEET: 4 OF 8			

6

5

4

3

2

1

Version	Checked By	Approved By	Date

D

D

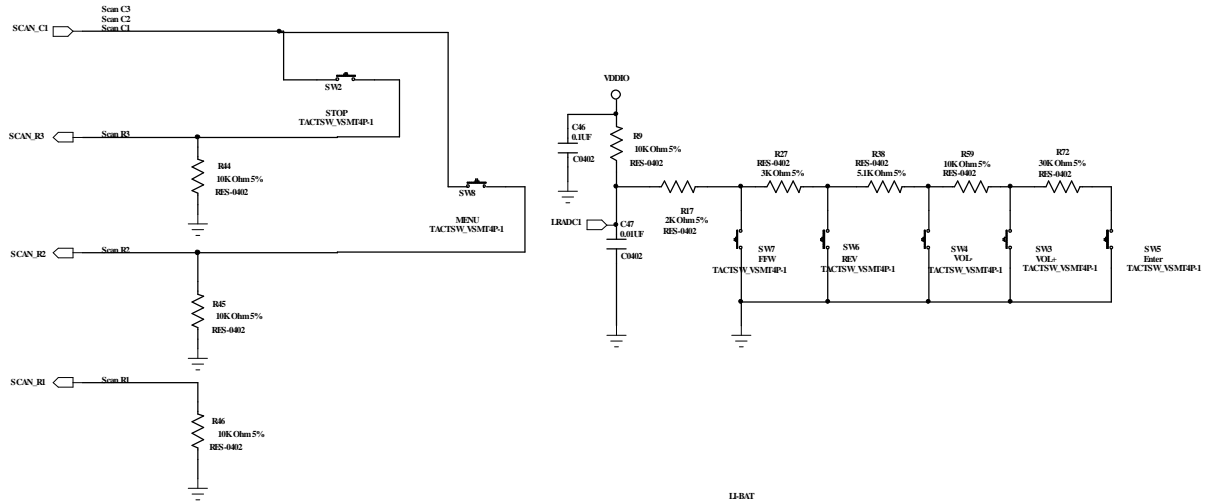

B

B

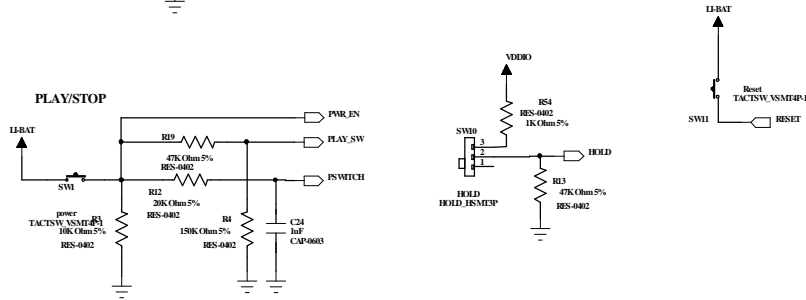

A

A

A-MAX Technology Co.Ltd

Title: Buttons			
Model	06FP05	Version	VER:LOW
Drawn By		Date	
Checked By		Date	
Approved By		Date	
SHEET: 5 OF 8			

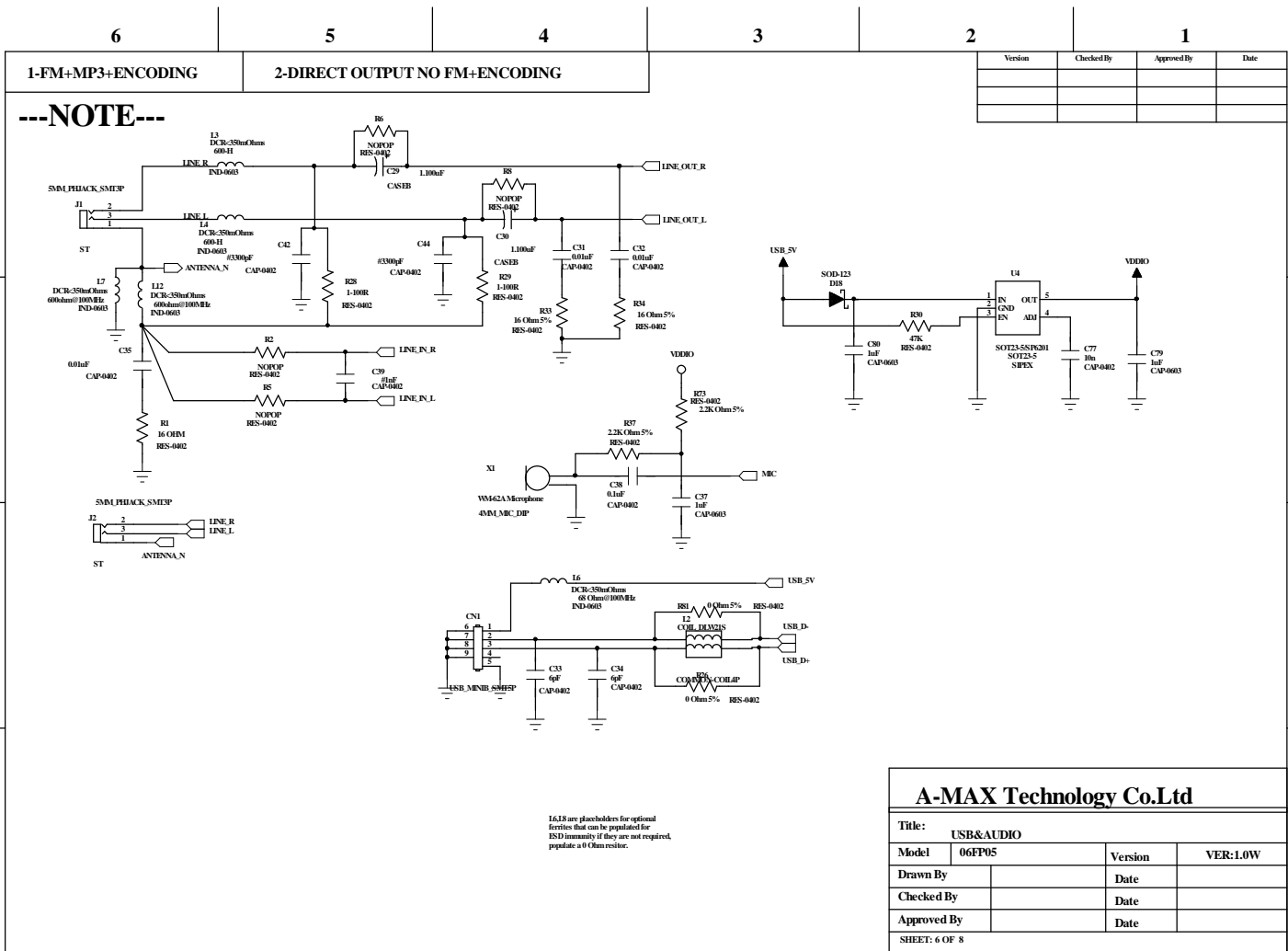

Version	Checked By	Approved By	Date

A-MAX Technology Co.Ltd			
Title: USB&AUDIO			
Model	06FP05	Version	VER:1.0W
Drawn By		Date	
Checked By		Date	
Approved By		Date	
SHEET: 6 OF 8			

6

5

4

3

2

1

Version	Checked By	Approved By	Date

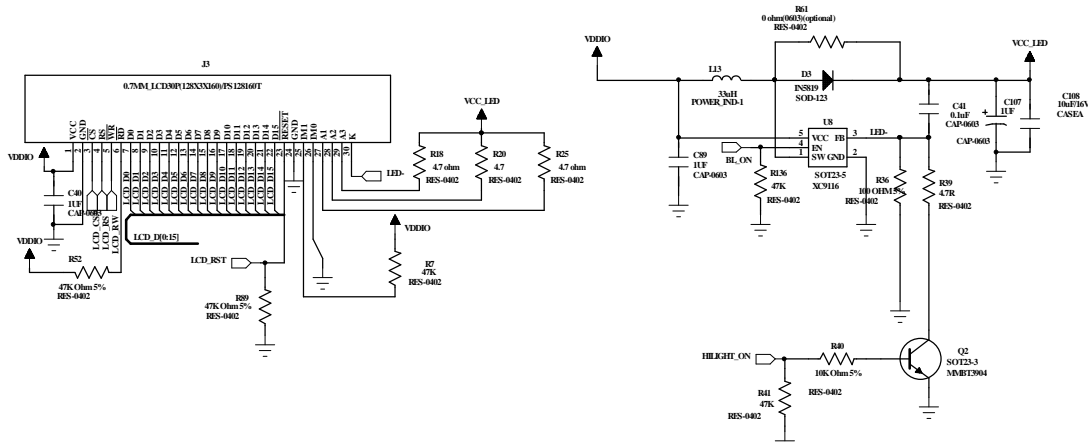

A-MAX Technology Co.Ltd			
Title: TFT LCD			
Model	06FP05	Version	VER:1.0W
Drawn By		Date	
Checked By		Date	
Approved By		Date	
SHEET: 7 OF 8			

6

5

4

3

2

1

Version	Checked By	Approved By	Date

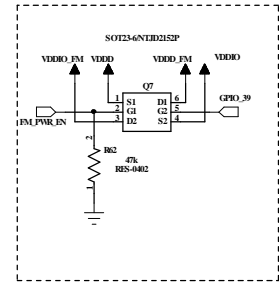
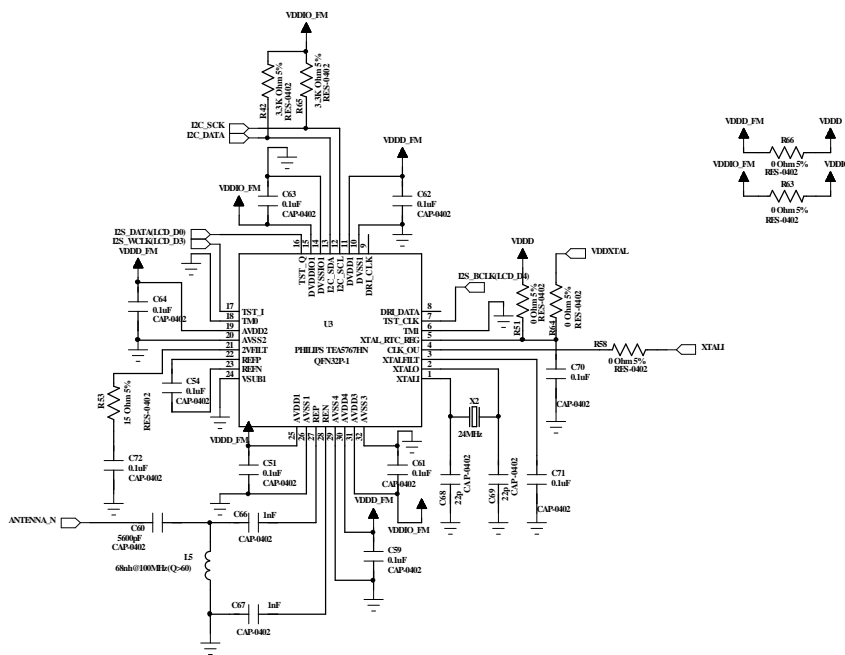

A-MAX Technology Co.Ltd

Title: FM TUNER			
Model	06FP05	Version	VER:1.0W
Drawn By		Date	
Checked By		Date	
Approved By		Date	
SHEET:8 OF 8			